



INSTITUTE OF THE
MOTOR INDUSTRY
Driving the industry since 1920



19/01/2021

IMI Webinar

What you need to know about the IMI's new eLearning platform

This Webinar will begin shortly



Introducing the Team



Chris Cotterill MIMI
**UK Business
Development Manager**



Steve Scofield FIMI
**Head of Business
Development**

Admin - Q&A

Please use the Q&A functionality to write questions:

- The IMI team will respond with as many answers as possible during and at the end of the presentation
- Any questions we are unable to answer during the webinar will be answered post event
- The Webinar will be recorded and made available to be used as a reference resource for you and your wider teams

Agenda

Discussion points include:

- Partnership background
- Why this is the evolution of learning
- Platform benefits for teachers, students, or anyone who wants to learn
- Phased launch for different types of access
- Content available and brief demonstration of platform

So Why the Vocanto Partnership

- The Partnership Investment and combined expertise enable IMI to lead the way globally
- Expertise and investment
- The combined offer from IMI, VOCANTO and its sister business Lucas Nuelle
- End to end solution
- Crossing borders & Time-zones - Multiple languages
- Pandemic solution

Supporting IMI Approved Centres and Members Around the World

- Responding to the rapid shift technological shift & need for up to date learning material - technology advancements
- Teachers, Trainers & Assessors
- Young learners
- Over 80,000 IMI Members

Phase 1 Launch, March 2021 (exact date TBC) – Licence Model

Training Provider
invests in an
annual licence for
platform access

Learner access will
be via redeem code
and their own MyIMI
account

Redeem codes are
available for EV
content only or EV &
LV content combined



Phase 2 Launch (date TBC) – Individual Modules

Content will be broken down to provide modular access

Available for Individuals or Organisations to pick & mix to meet their needs

Learner access will be via redeem code and their own MyIMI account



What EV Content is Available?

12 subject areas



65 Lesson Modules

The screenshot displays the IMI learning platform interface. At the top, it shows the course 'Pilot project' with 63 XP / 335 XP. Below this, a sidebar lists 'Electric vehicle' and 'Light vehicle'. The main content area shows the 'Electric vehicle' course (31 XP / 105 XP) with a sub-unit 'Drive Configurations/Hybrid and EV Types' (21 / 80 XP). A progress bar at the bottom indicates 'Answered questions: 7 / 16' with a green bar for 37.5% and a red bar for 6.2%.

Question	XP
1st Belt Starter Generator/Belt Alternator Starter	4 / 10 XP
2nd Mild Hybrid	5 / 15 XP
3rd Medium Hybrid	0 / 15 XP
4th Strong/Full Hybrid	0 / 10 XP
5th Plug-In Hybrid	0 / 15 XP
6th Electric Vehicle	12 / 15 XP

What EV Content is Available?

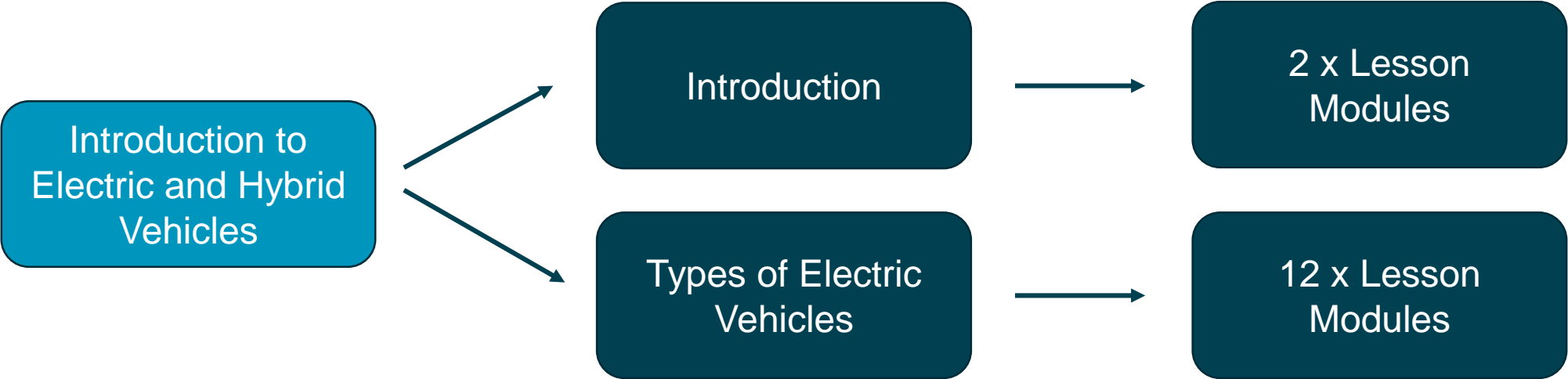

What EV Content is Available?

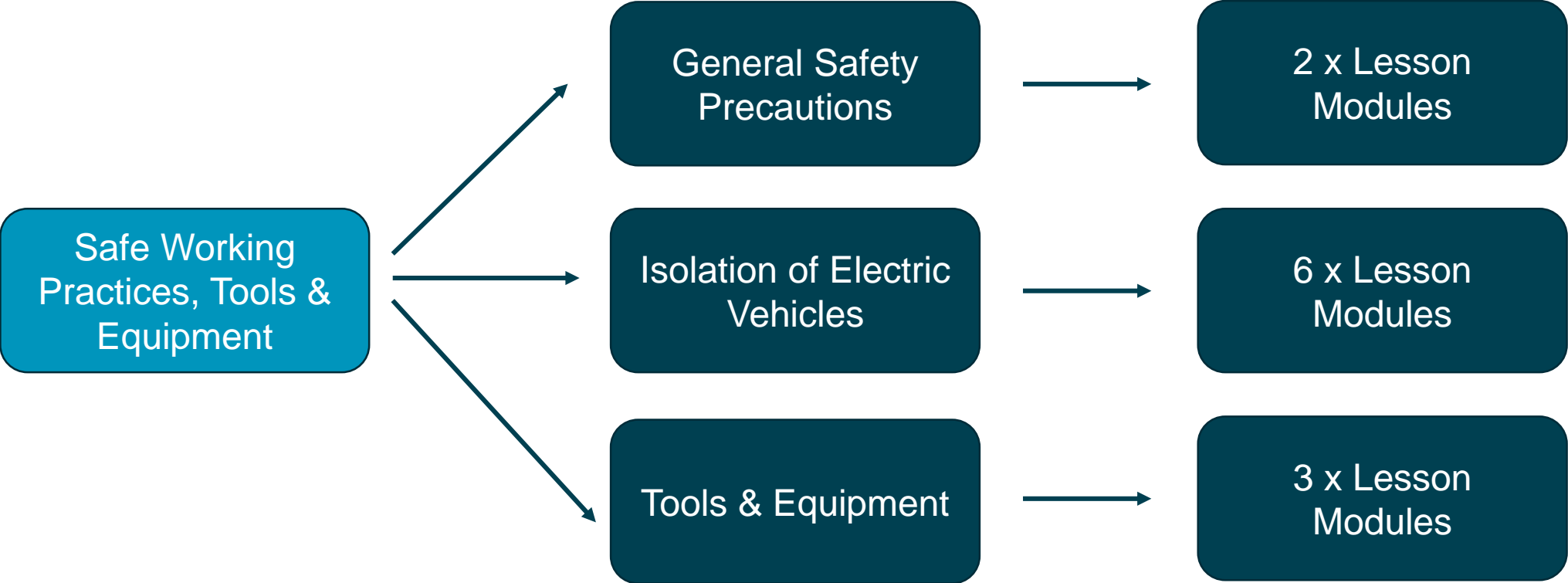

What EV Content is Available?

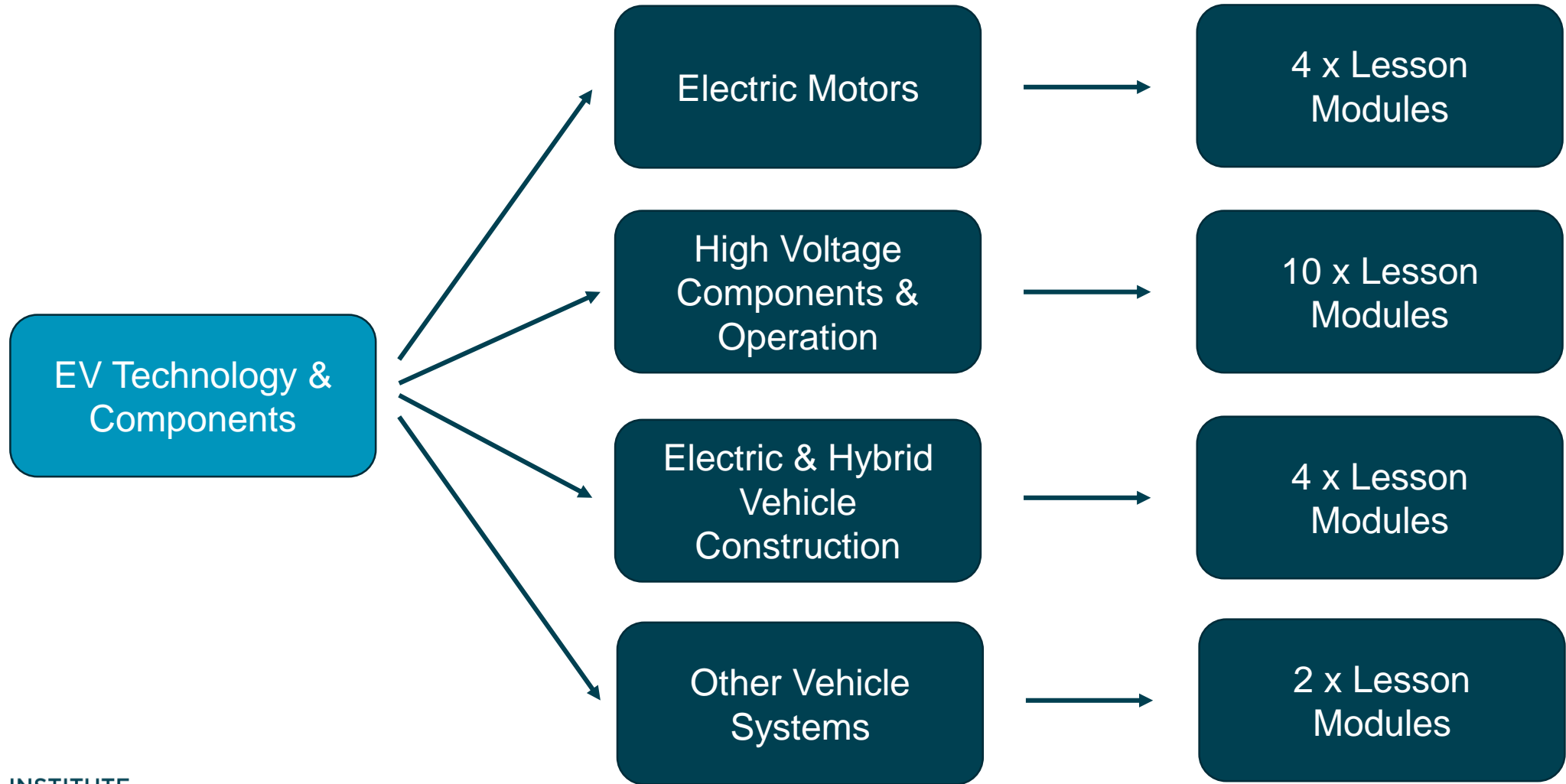

What EV Content is Available?

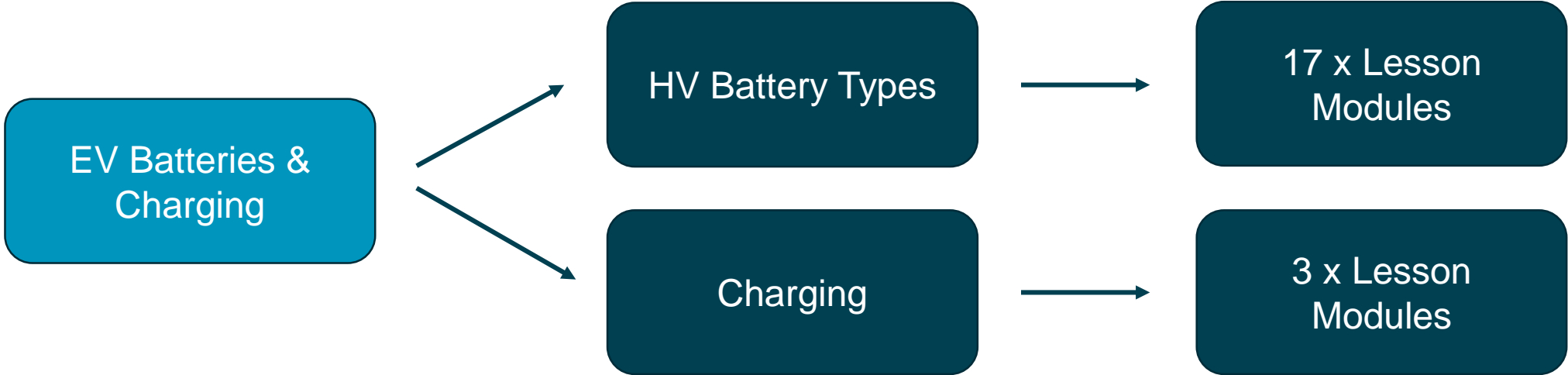

What LV Content is Available?

Electrical	Engine	Transmission	Air Con	Chassis	Foundation Units
19 Subject Areas	9 Subject Areas	5 Subject Areas	4 Subject Areas	10 Subject Areas	4 Subject Areas
140 Lesson Modules	94 Lesson Modules	25 Lesson Modules	19 Lesson Modules	39 Lesson Modules	30 Lesson Modules

What does the platform look like?

Live Demonstration



INSTITUTE OF THE MOTOR INDUSTRY
Driving the industry since 1920

Search IMI Students My IMI Basket Become a member

Industry Latest Learn Apprenticeships & EPA Careers Membership About the IMI

Enter your access code

If you need to redeem this booking for someone other than who you are currently logged in as, please [log out](#) first and restart this process.

[Redeem Code](#)

Already redeemed your code?

If you have already redeemed your code, please [access your course](#) »

[Download our access guide](#) »

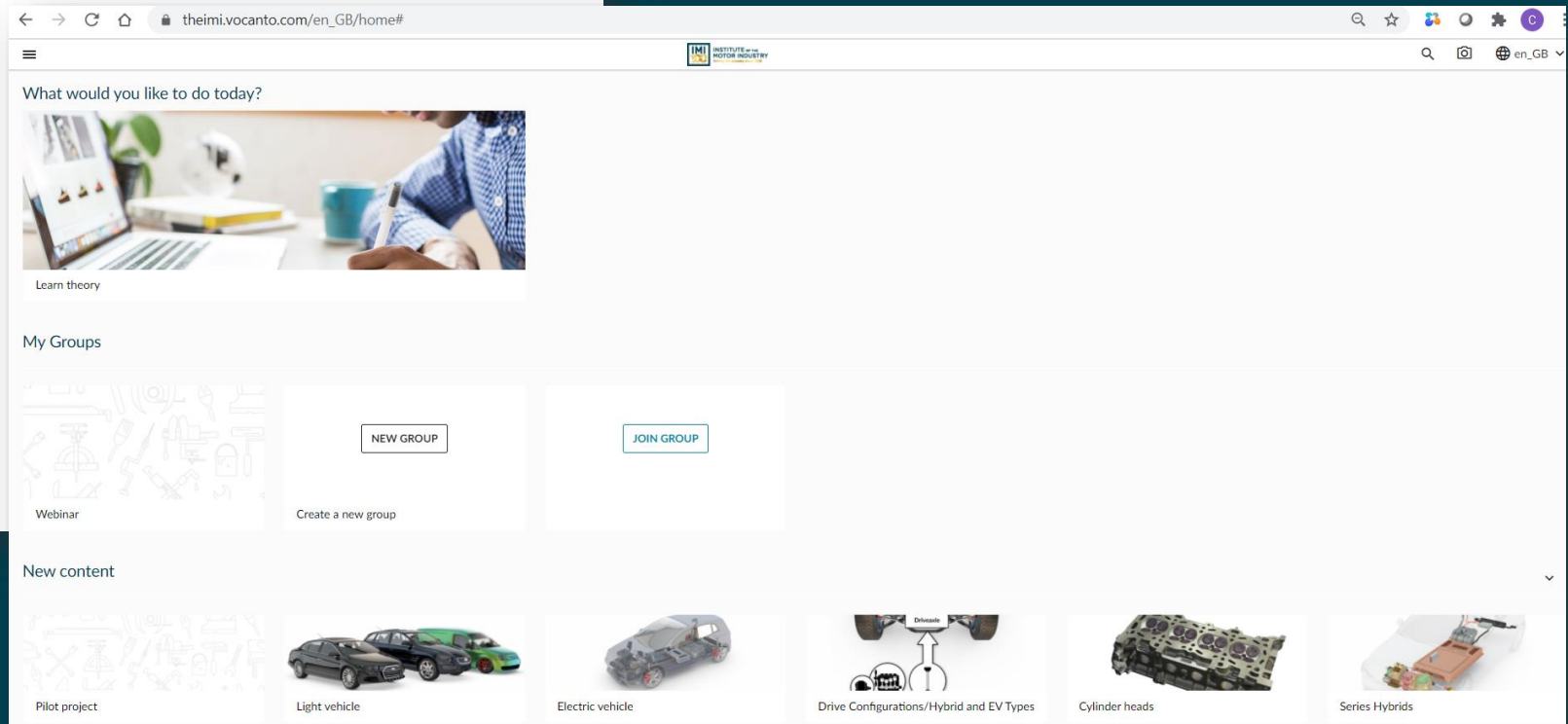

theimi.vocanto.com/en_GB/home#

What would you like to do today?



Learn theory

My Groups

Webinar Create a new group JOIN GROUP

New content

Pilot project Light vehicle Electric vehicle Drive Configurations/Hybrid and EV Types Cylinder heads Series Hybrids



INSTITUTE OF THE MOTOR INDUSTRY
Driving the industry since 1920

Next Steps

- The IMI Product Development and eLearning Teams continue to work with their Vocanto counterparts to operationalise and integrate systems ready for launch
- Current live pilots with different customer types will provide valuable insights to inform the operational model
- The Business Development team will make contact with those organisations who registered their interest following the December soft launch campaign
 - We can provide further demonstration
 - Discuss and agree commercials
 - Provide system access
- Web page development and marketing campaign leading to a hard launch end of March (exact date TBC)



Q&A